

# EPS.LUMI 2000

Technical Documentation

11.2024

	Page
Basic knowledge	
Fabric allowance LUMI	4
Attachement of the flex holder	5
Fabric tensioning	6 - 7
Assembly boxes	
BOX S-120 and BOX S-180	9
Broad Cover profile	10
BOX D-200	11
Weldable retrofit	12
BOX S-85 and BOX S-112	13
BOX S-84 and BOX S-97	14
Profile joint Box S-97	15
DISPLAY S-85 and DISPLAY S-112	16
DISPLAY S-84 and DISPLAY S-97	17
Technical additional information	
Statics and special designs	19
Order information for kits	20
Systematic presentation of supports	21
Assembly instructions of the fabric surface for displays	22
Edges	23
Bending	24

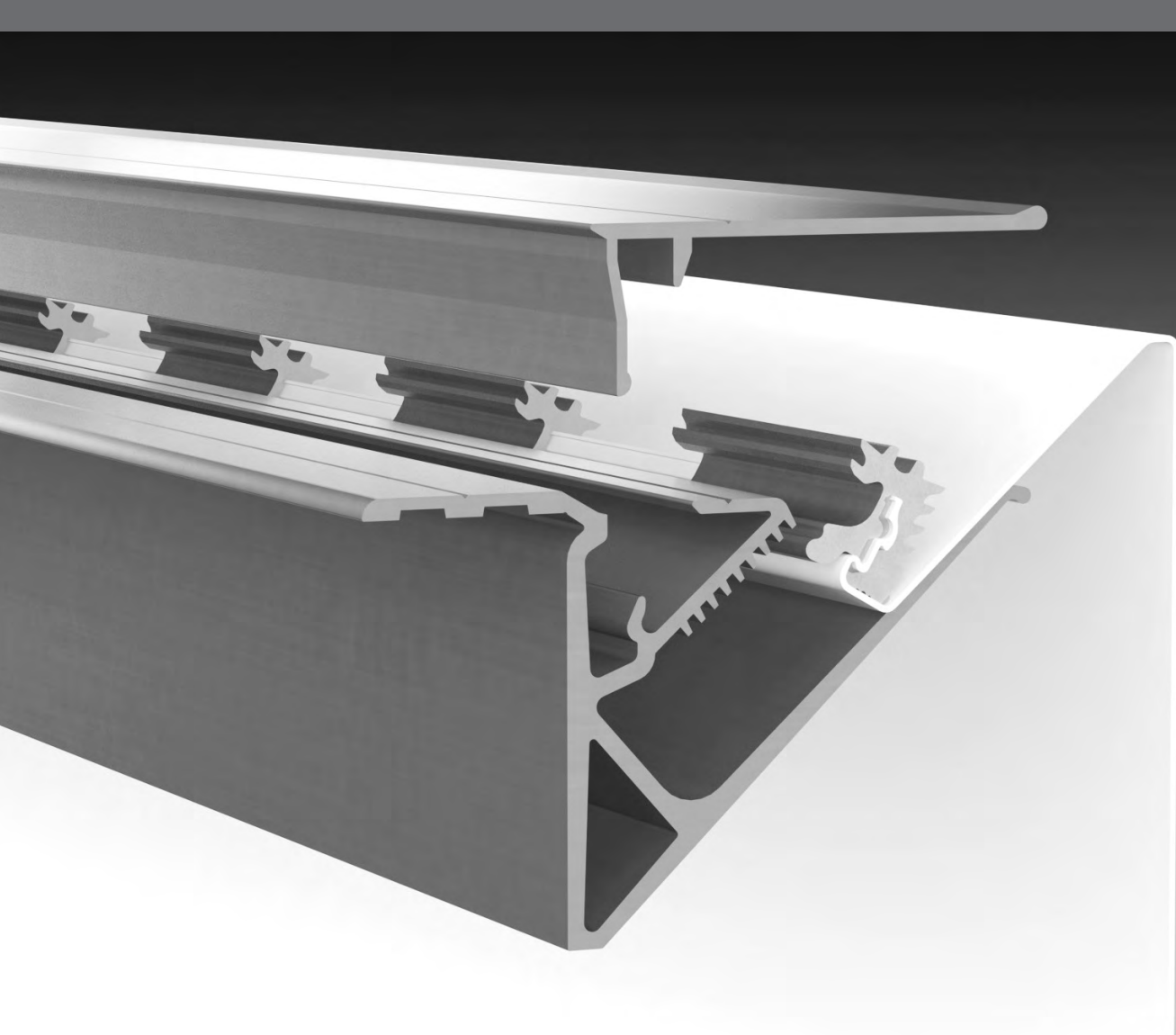

**Basic knowledge  
Fabric tensioning**

The front side of all of the profiles has a frameless design, meaning that the motif can run right up to the outer edge of the profile. The fabric is clamped and unclamped at the side.

**Fabric allowance and fabric cutting with frameless flat cover EPS 1-022 and EPS 1-023**

Add **63 mm fabric allowance** to the outer dimension of the assembled housing all around.

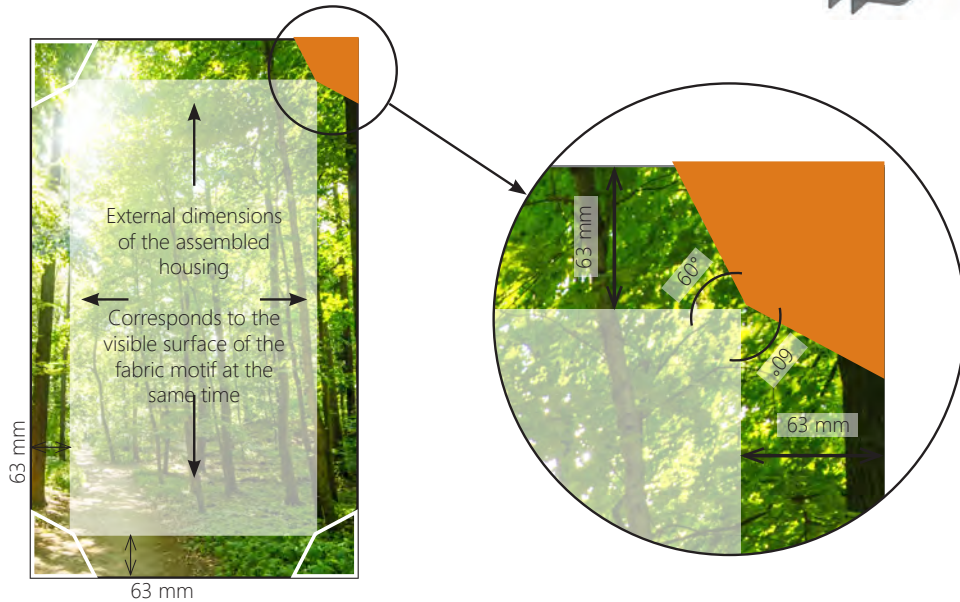
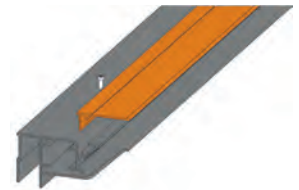

Add 63 mm to the external dimensions of the housing.

Remove the orange area of the fabric.

**Fabric allowance and fabric cutting with broad cover profile EPS 1-300 and EPS 1-301**

Add **59 mm fabric allowance** to the outer dimension of the assembled housing all around.

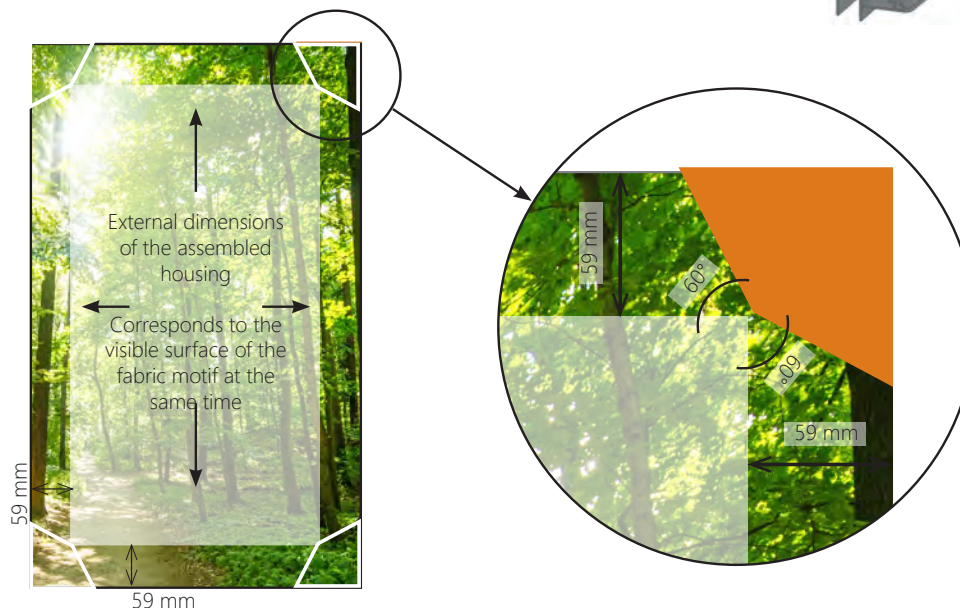
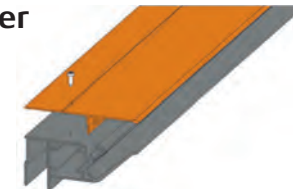

Add 59 mm to the external dimensions of the housing.

Remove the orange area of the fabric.

## Notes on the mass per unit area of the fabric

The mass per unit area of a PVC coated polyester fabric should be at least 550 grams/square metre. In the event of a lower mass per unit area, the edge may need to be reinforced because the flexholder does not grip.

For formats with a length > 4 m, we recommend cutting the precise fabric allowance on site when in a half-tensioned state and then clamping the flex holders into place since temperature differences may influence the size of the fabric. If the fabric is still too long, release the flex holders with the flex holder pliers and cut the fabric down again.

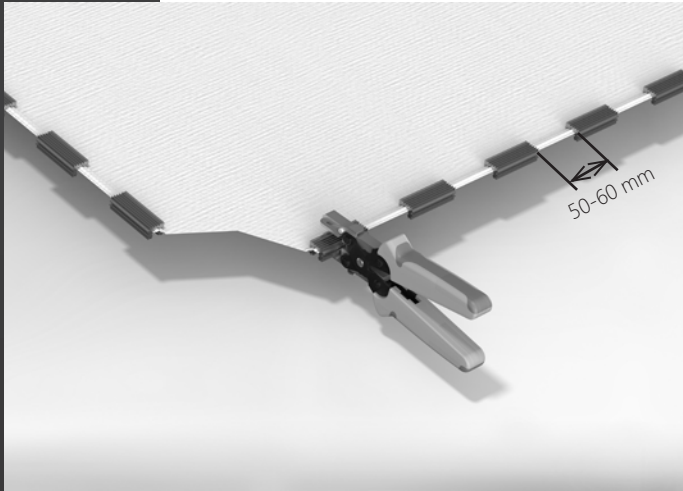

Starting from the corner of the fabric, the flex holders are applied with gaps of 50 - 60 mm between them. In order to achieve optimum tension: the larger the fabric area, the smaller the gaps between the holders.

Using the flex holder pliers, compress the flex holder on the fabric until it engages perceptibly. Important: The flex holder must, as shown, have the finely toothed side facing the visible area of the fabric when clamping.

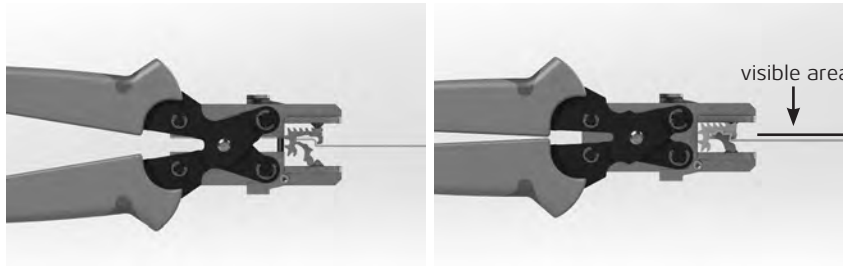

To open the flex holder, the clamping lug of the flex holder must be bent open in the opposite direction.

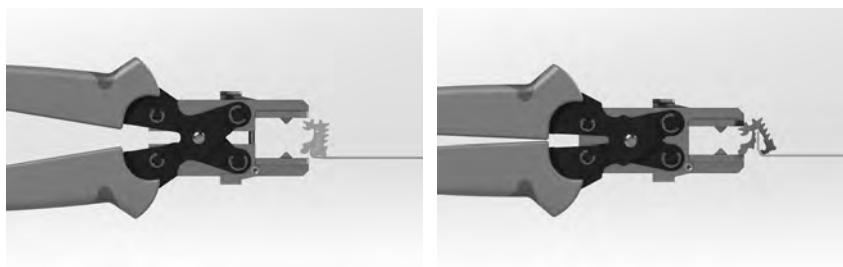

In order to be able to clamp the fabric correctly, the flex holder is folded once in the direction of the visible area and then inserted in the clamping channel of the profile!

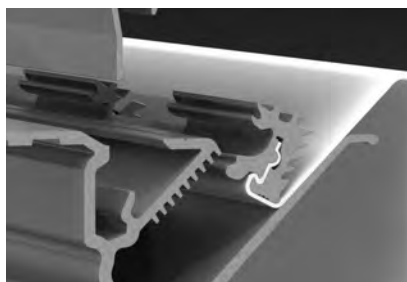



When installing PVC coated fabric a minimum ambient temperature of 8° Celsius should be ensured. In the event of lower temperatures, the fabric may buckle or be damaged in other ways. For small and medium formats, do not tension the fabric too firmly.

For formats with a length > 4 m, we recommend cutting the precise fabric allowance on site when in a half-tensioned state and then clamping the flex holders into place since temperature differences may influence the size of the fabric. If the fabric is still too long, release the flex holders with the flex holder pliers and cut the fabric down again.

Do not equip the frames with fabric when they are lying down since the fabric sags as a result of its own weight and you will thus have difficulties engaging the flex holders in the LUMI profile. In order to ensure optimum tensioning, always ensure the frame is upright.



Insert the first three flex holders on the sides and the top edge and engage into the first or second tooth of the profile. When inserting each flex holder pull the fabric firmly away from the starting point in order to prevent wrinkles.

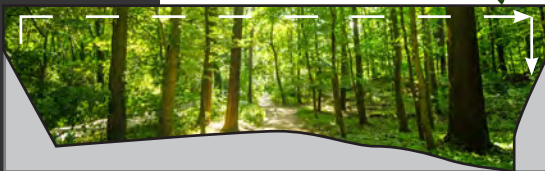

To finish the top row, insert the first flex holder on the opposite side and engage.



Finish inserting the side flex holders and engage into the first or second tooth.

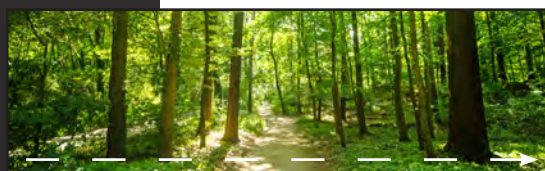

Insert the bottom flex holders and engage into the first or second tooth. Only when this step is completed may you start actually tensioning using tensioning tools.

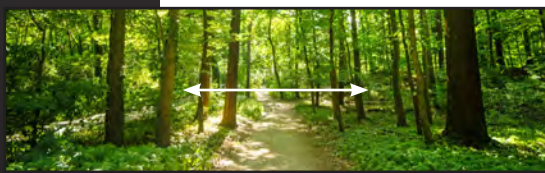

Use a tensioning fastener to push the flex holders on the left and right deeper into the profile and thus to tension the flex.

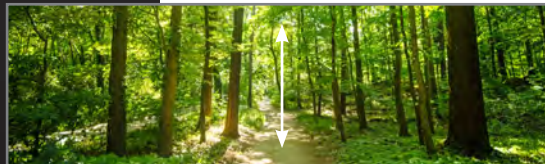

Then push the flex holders along the top and bottom edges deeper into the profile. If necessary, go round all flex holders again and tension further.

**Minimum tensioning depth of the flex holder**

In order to ensure that the fabric is provided with optimum and secure tension when you have completed tensioning, the flex holders should be engaged in the middle section of the toothing of the tensioning profile.

The fabric can be tensioned in two ways:

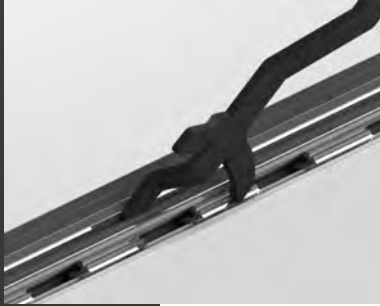
**1. With the tensioning tool**

Insert the nipple at the centre tip of the tensioning tool into the profile groove above the tensioning channel. Press down the left or right tip of the tensioning tool to engage the flex holder in the teeth of the tensioning channel and tension the fabric. Then seal the tensioning channel with the cover profile and use screws to prevent it from springing off unintentionally.

Important: The tensioning tool cannot be used with LUMI GRIP profiles.

**2. Tensioning with flex holder fastener and rubber hammer**

In order to securely tension the fabric, apply the flex holder fastener like a chisel to the flex holder and use the mallet to drive it deeper into the profile. For small and medium formats, do not tension the fabric too firmly.

Then seal the tensioning channel with the cover profile and use screws to prevent it from springing off unintentionally.

**Releasing the fabric**

The cover profile can be removed from the profile using the profile remover. To release the flex holder, use a wide screwdriver to lever the flex holder from the tensioning profile, thus disengaging it and allowing it to be removed from the tensioning profile along with the fabric.

**IMPORTANT NOTE:**

When using black or dark fabrics, as well as those where the entire surface has dark print or lettering, the heat generated as a result of direct sunlight may cause wrinkles to appear.



**EPS**  
SYSTEMS

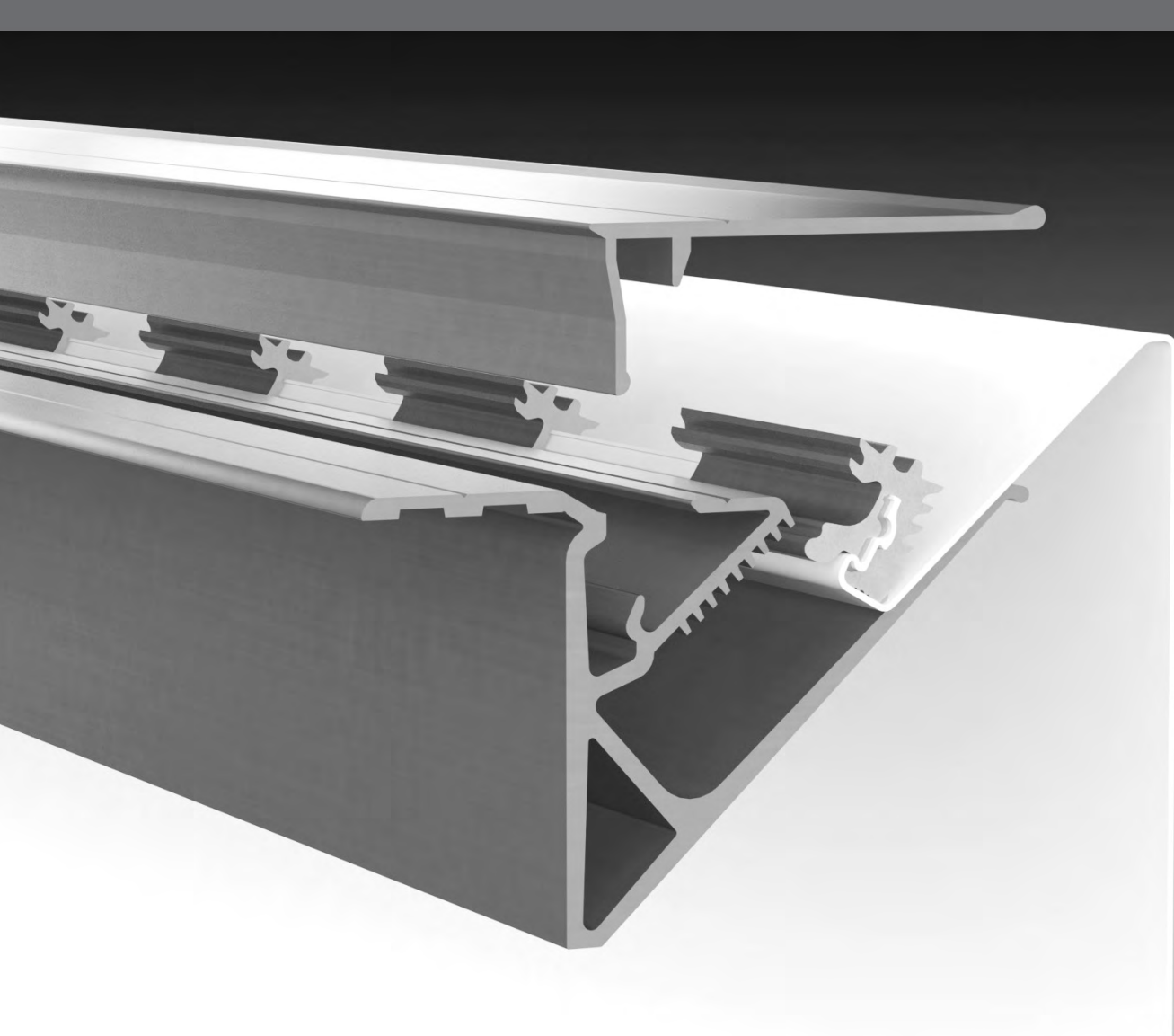

**Assembly Boxes**

The following assembling instruction shows the profile assembling using the example of the BOX S-120.

Please note:

- Fabric allowance circumferential 63 mm
- When using the broad cover profile the circumferential fabric allowance is reduced on 59 mm
- Always secure the cover profile with screws.
- Notes on bending see page 24.



### Edge

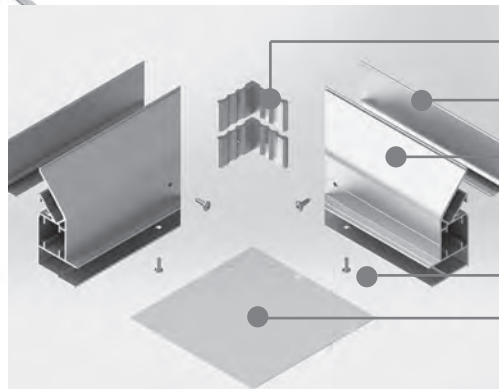

- Corner angle EPS 1-041, 2 pieces per edge
- Cover profile EPS 1-022
- Main body120 EPS 1-006
- Screwing rear wall
- Rear wall, material thickness 2 mm, cut 60-65 mm shorter than the overall housing height

### Profile joint

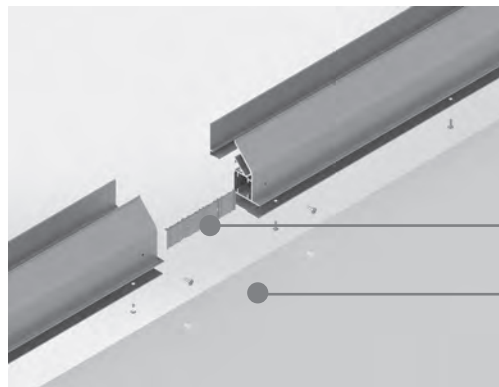

- Joiner plate EPS 1-040
- Rear wall

### Stiffening

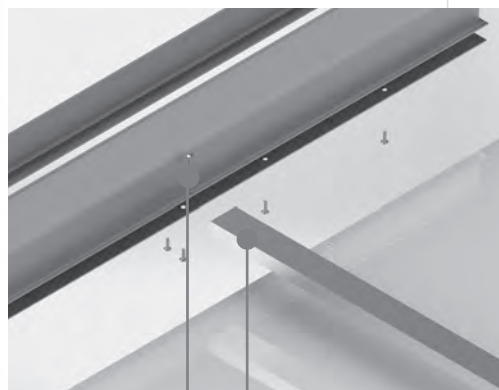

- Screwing on profile

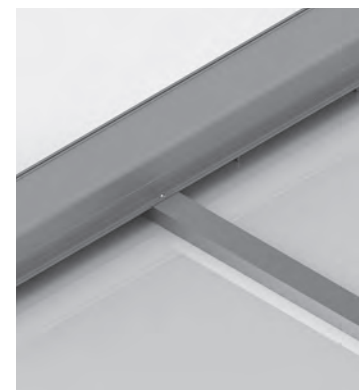

When using the flat cover profile EPS 1-022, cut aluminum tube EPS 1-054 **approx. 5 mm shorter than the frame format** and insert into the corresponding groove.

When using the wide cover profile EPS 1-300 and EPS 1-301, **cut approx. 9 mm shorter.**

With the wide cover profiles EPS 1-300 and EPS 1-301 a closed look of the frame is achieved.

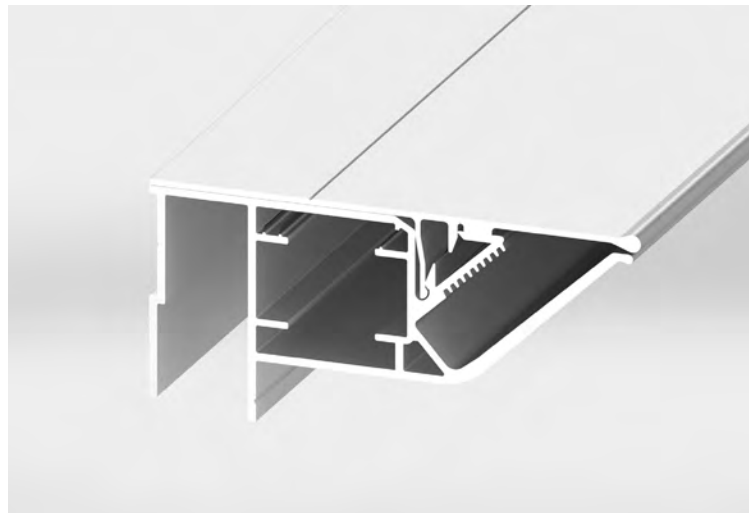
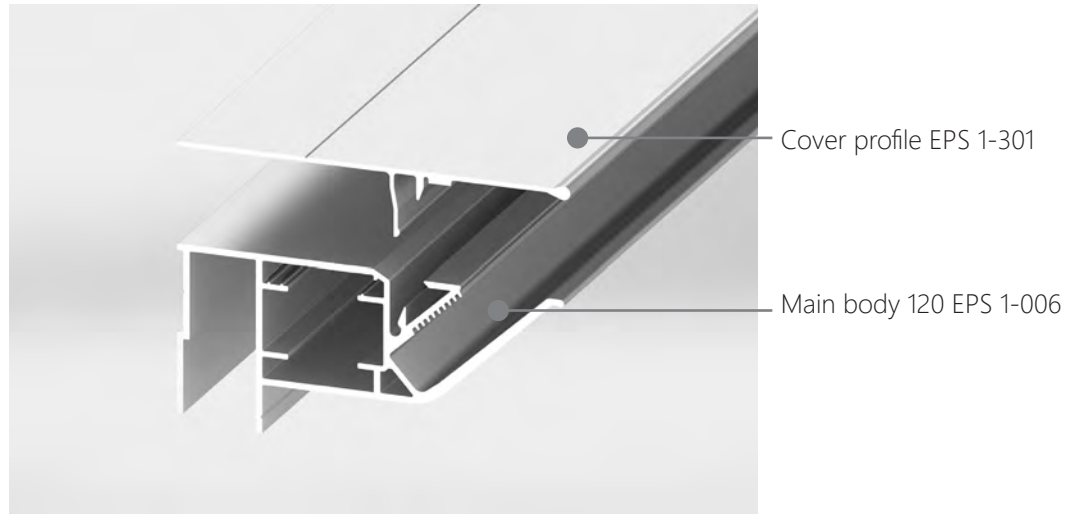

The Main body therefore no longer has to be surface-treated.  
It is also possible to change the color of the visible profile frame without dismantling and repainting the entire advertising structure.  
The cover profiles are available in raw aluminum and in colorless anodized E6 / C0.

**Please note:**

When using the broad cover profile the circumferential fabric allowance is reduced on 59 mm.

In addition, the aluminum tube EPS 1-054 must be cut approx. 9 mm shorter than the frame format.

Please note:

- Fabric allowance circumferential 63 mm
- First, snap the fabric on both sides in the First row, then tense both sides alternately.
- Always secure the cover profile with screws.



### Edge

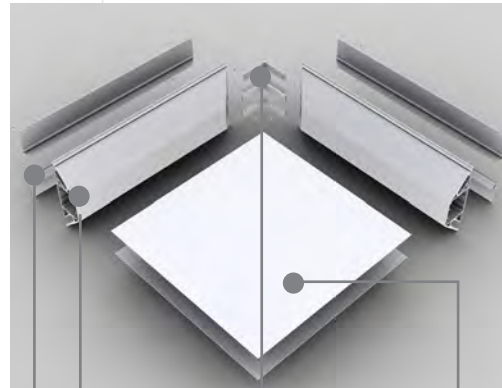

Corner angle EPS 1-080,  
4 pieces per edge

Main body double-sided  
EPS 1-007

Cover profile EPS 1-023

Rear wall

Self-made reinforcement of welded square tube 40/40/3 mm.  
Reinforcement is to be selected by the processor himself

### Profile joint

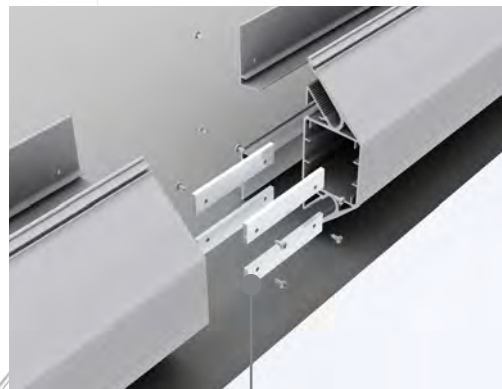

Joiner plate EPS 1-081, 4 pieces per joint

Please note:

- Fabric allowance circumferential 63 mm
- Always secure the cover profile with screws.
- The profile EPS 1-011 cannot be bent.

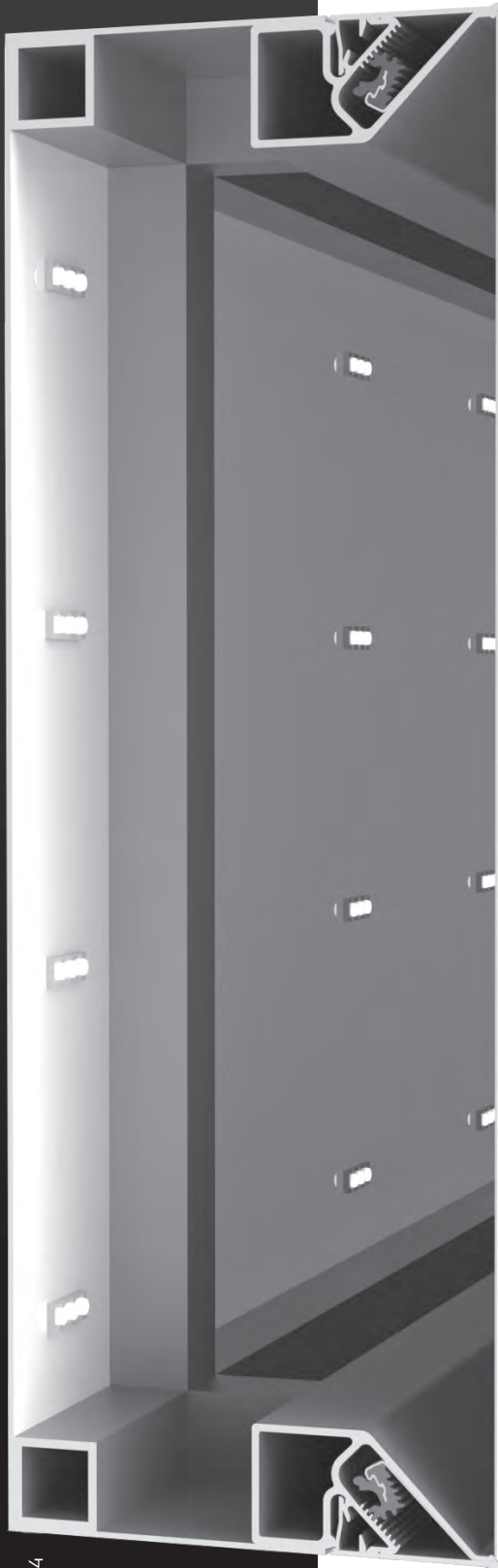

### Edge

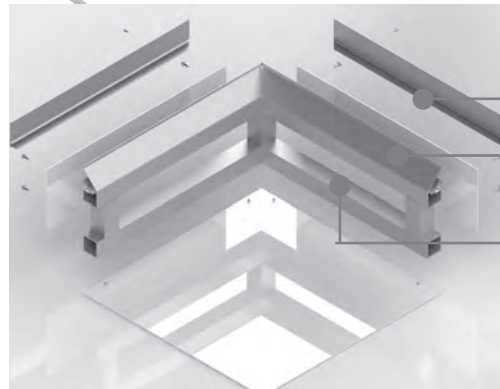

Cover profile EPS 1-022

Retrofit EPS 1-011

Substructure



Self-made reinforcement of welded square tube. Reinforcement is to be selected by the processor himself.

### Double-sided frame



The following assembling instruction shows the profile assembling using the example of the BOX S-84.

Please note:

- Fabric allowance circumferential 63 mm
- Always secure the cover profile with screws.
- Notes on bending see page 24.



### Edge

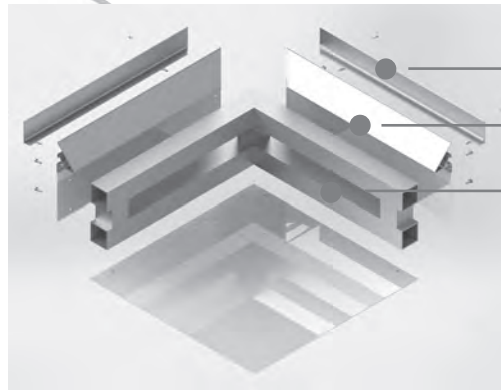

Cover profile EPS 1-022

Retrofit EPS 1-017

Substructure

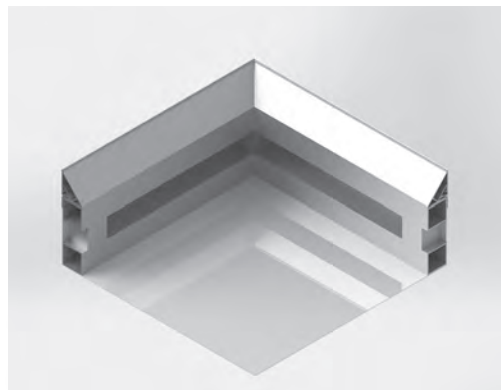

Self-made reinforcement of welded square tube. Reinforcement is to be selected by the processor himself.

### Double-sided frame (BOX D-84 und BOX D-97)





For the connection of the Retrofits EPS 1-019, the Joiner pin EPS 1-079 can be used.

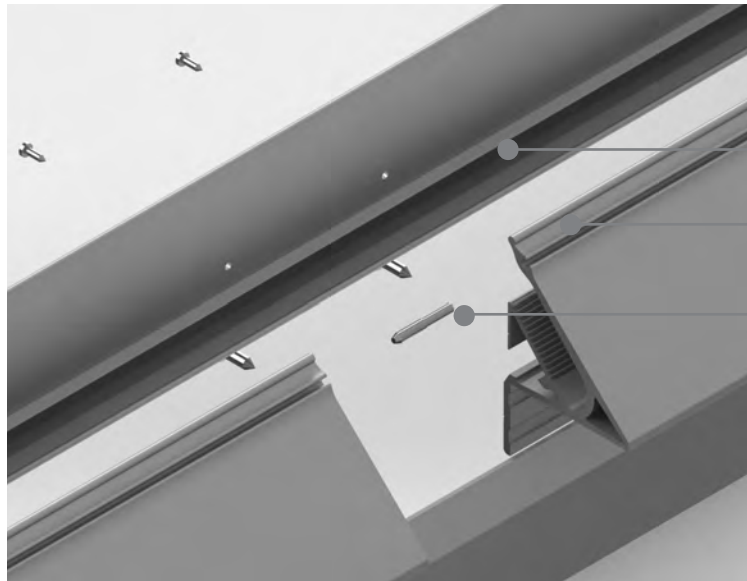

Cover profile EPS 1-023

Retrofit EPS 1-019

Joiner pin EPS 1-079

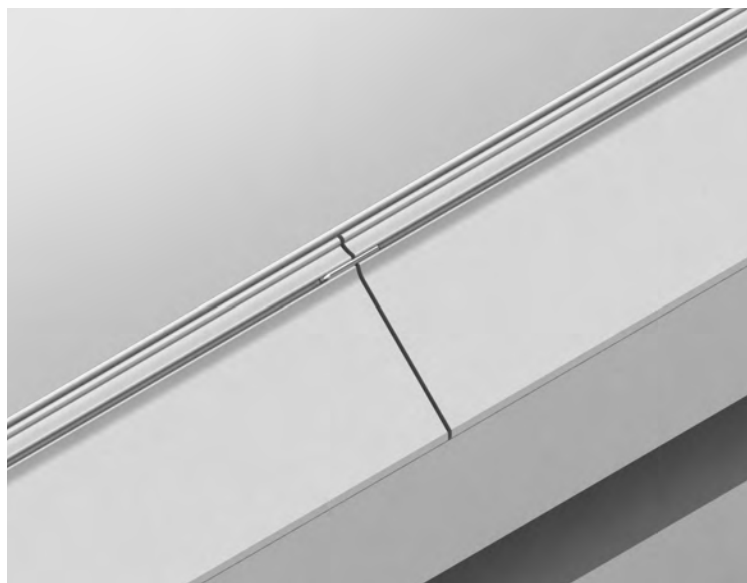

The following assembling instruction shows the profile assembling using the example of the DISPLAY S-84.

Please note:

- Fabric allowance circumferential 63 mm
- Always secure the cover profile with screws.
- Assembly instruction display on page 23.
- Notes on bending see page 24.

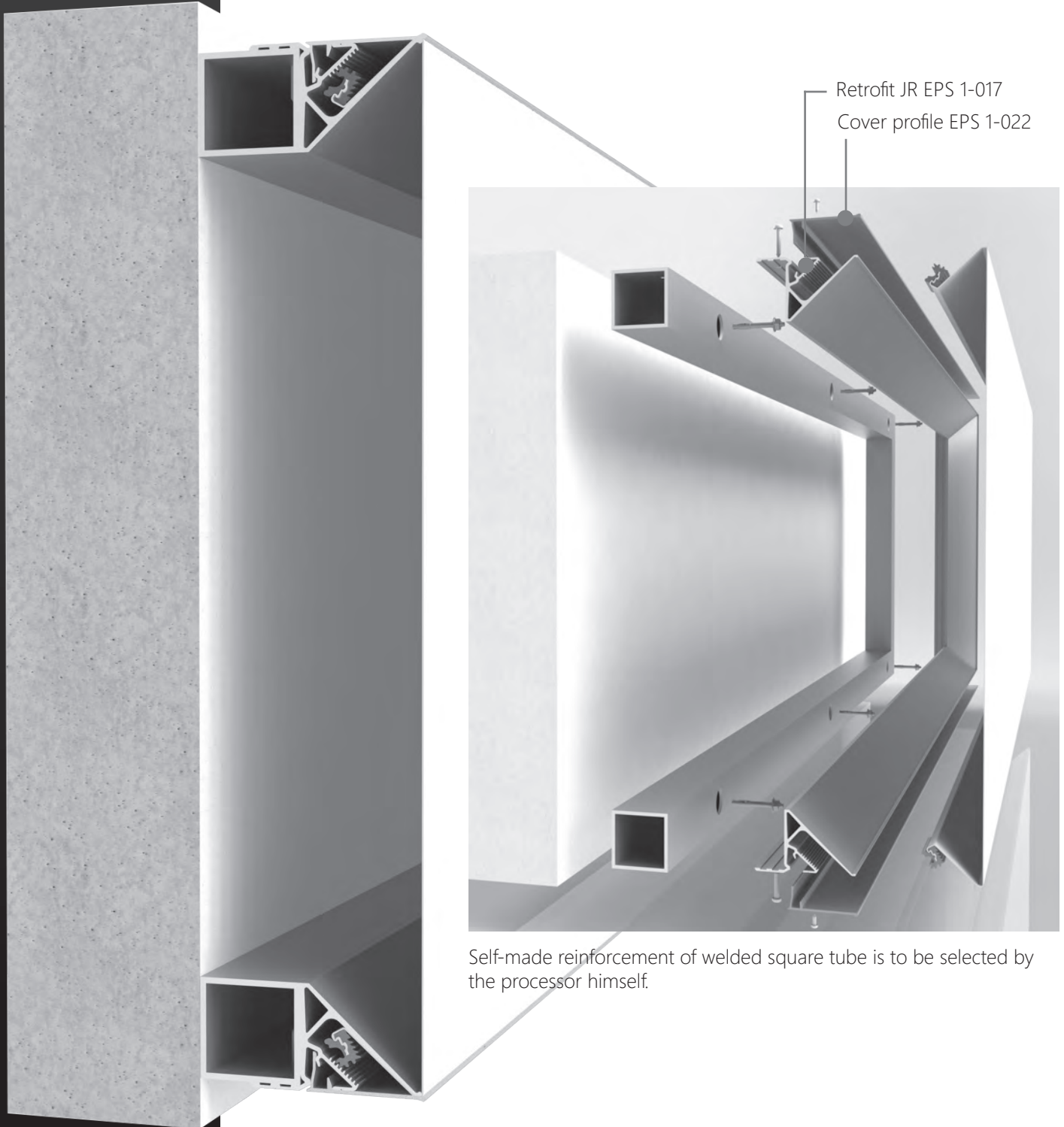

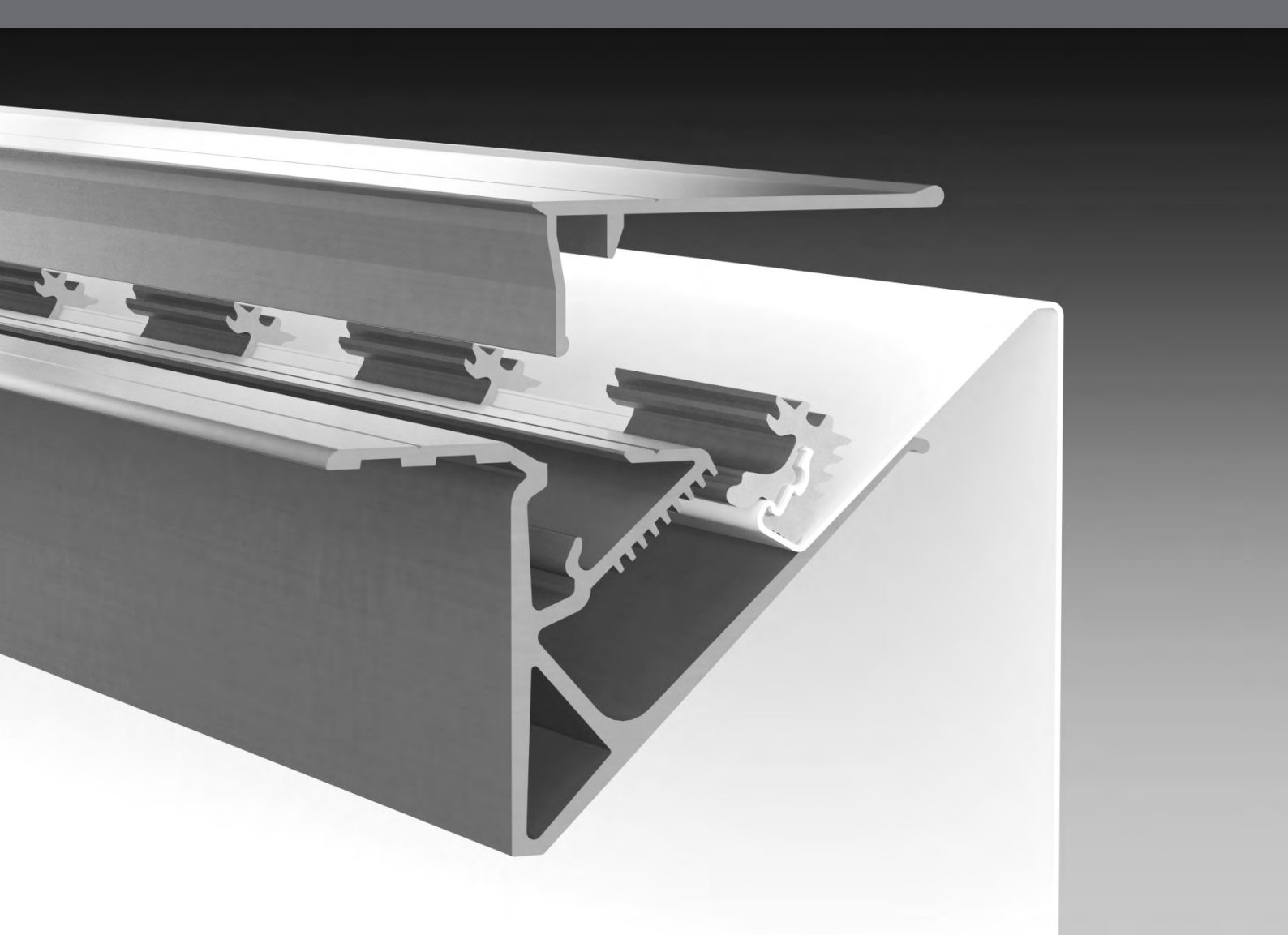

Technical additional  
information

### Static

For large format flex systems and exposed placements on high buildings or in the vicinity of the coast, you will require precise information regarding the performance capabilities of our tensioned profile systems.

We have subjected our profiles to comprehensive testing by independent test institutes and will be happy to assist you with our knowledge, expertise and static values regarding tension testing.



### Special profiles

If you can not find the right profile in our product range, we also offer the possibility of project-related special profiles.

We are happy to advise you on these topics.

Please note the following dimensions for kits and frames:

EPS 1-017 Retrofit AP 84  
EPS 1-019 Retrofit AP 97

$t = 2,5 \text{ mm}$   
 $t = 3-4 \text{ mm}$

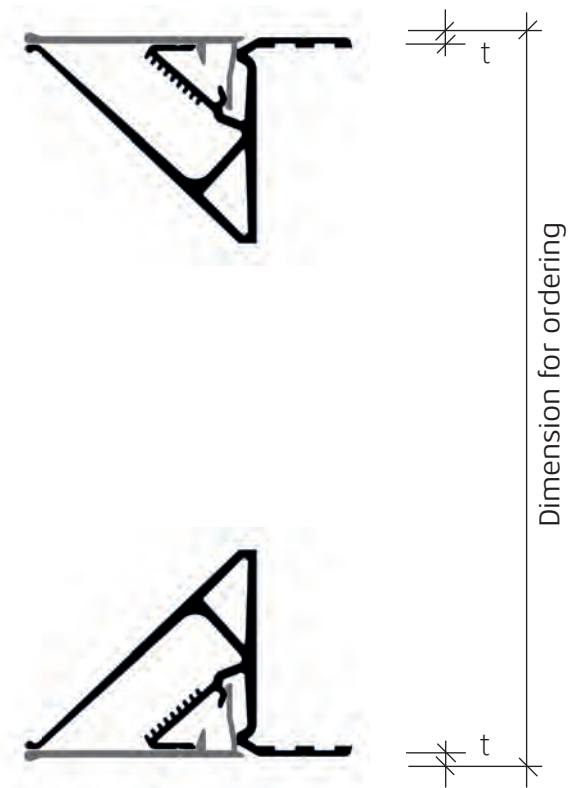

The following illustrations apply only to the BOX S-120 and BOX S-180

The support is fastened by using the Cross connector EPS 1-056.

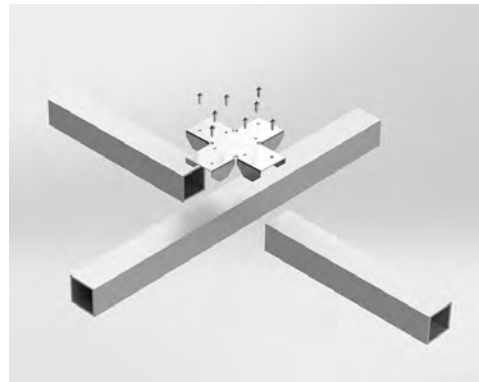
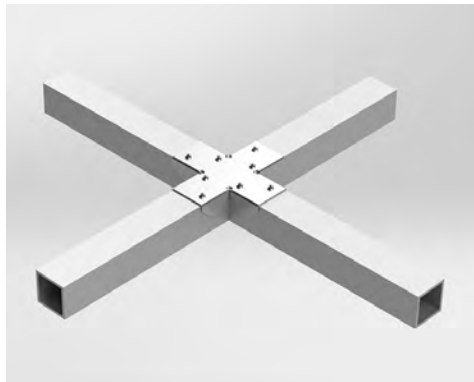



These notes refer to unlit displays with Retrofit.

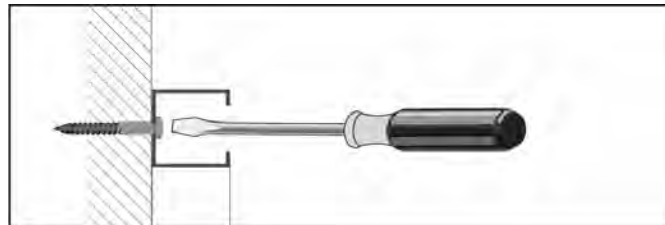
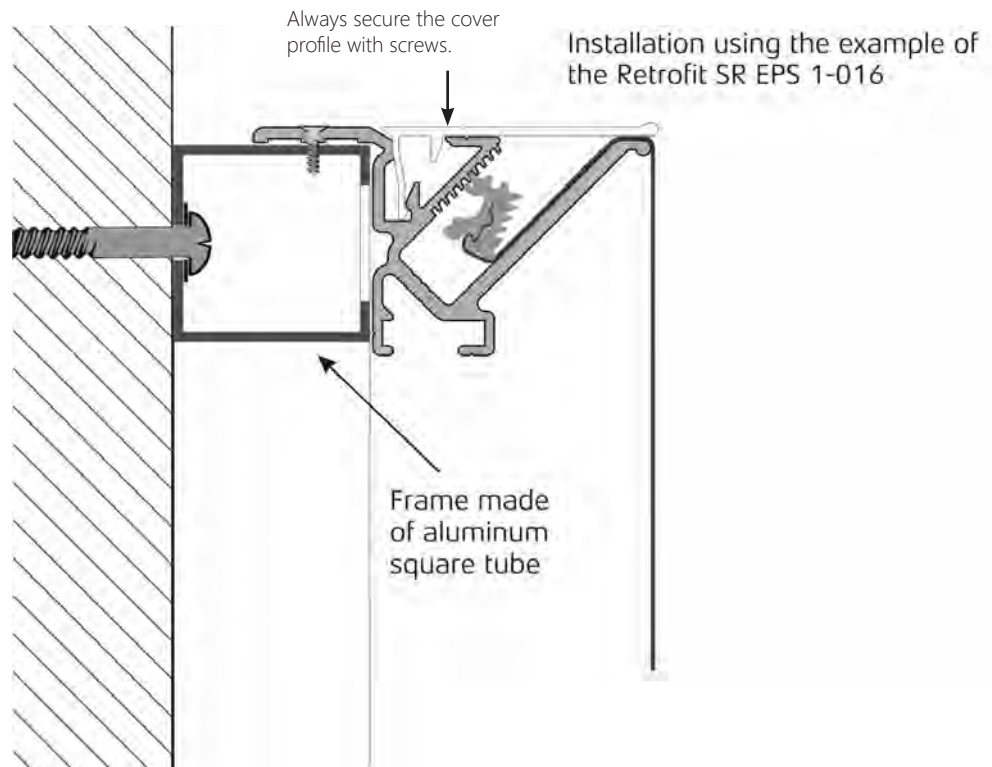

1. Mount square tube

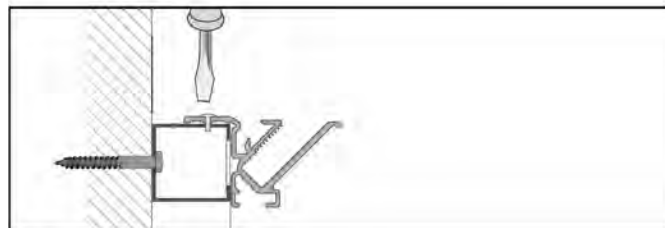

2. Mount retrofit

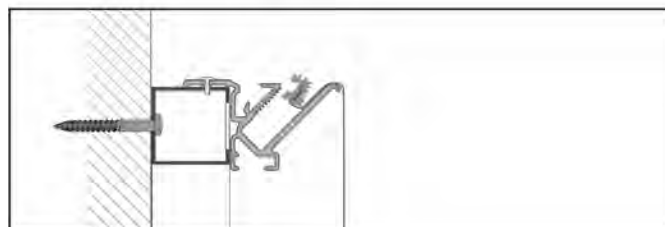

3. Tense fabric

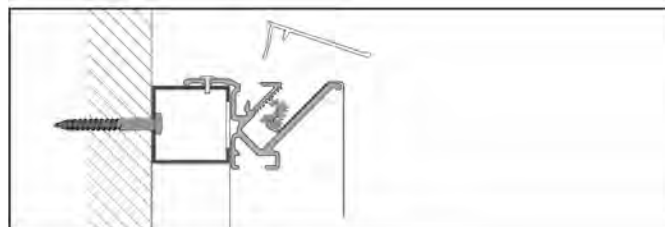

4. Fit and screwing of cover profile



Corner & Devider  
EPS 1-028



Exterior corner  
cover  
EPS 1-029



Devider cover  
EPS 1-030



Interior corner  
cover  
EPS 1-031

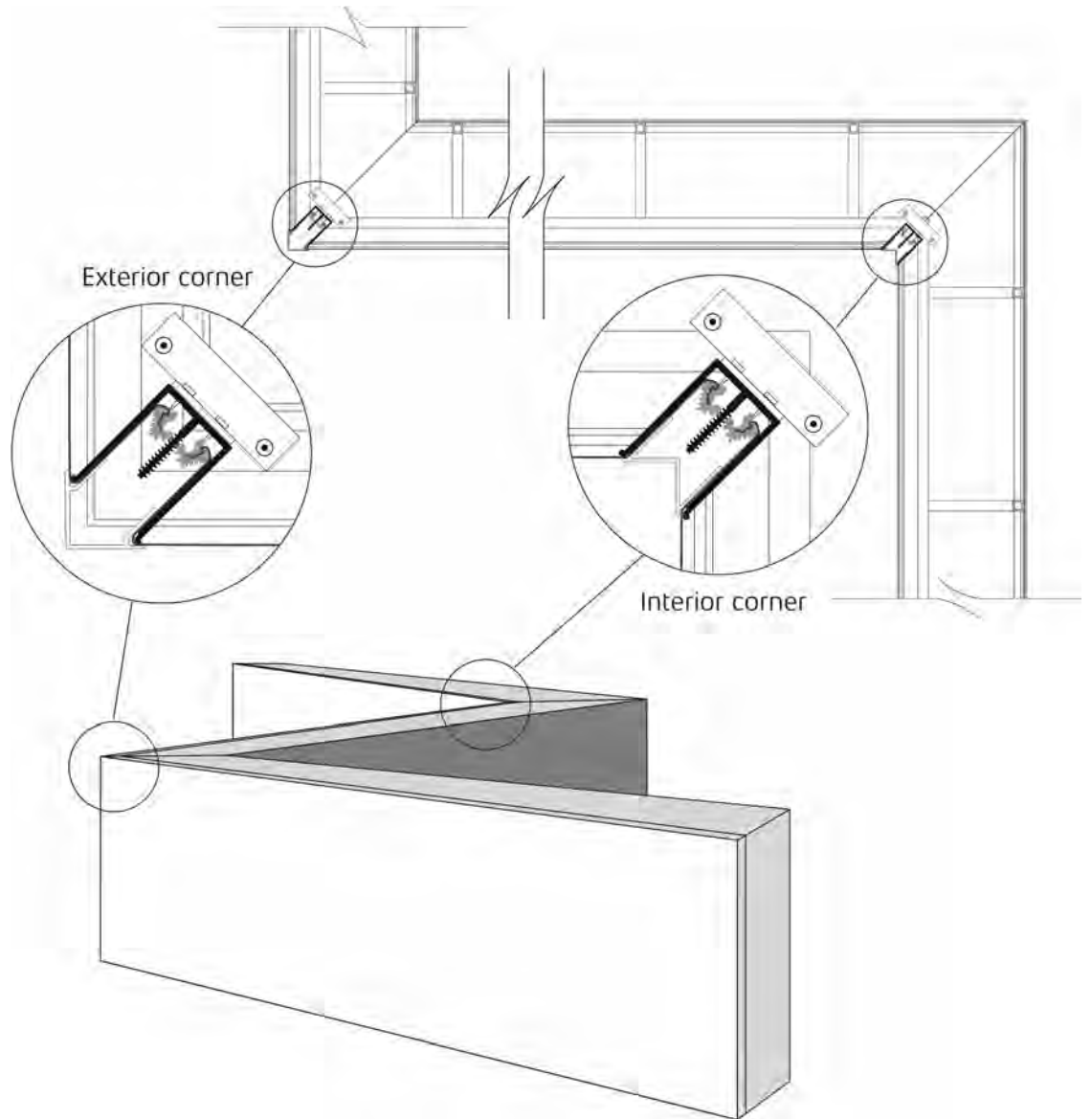

## Bending

As part of our „Profil.Plus“ service, we can shape your profiles to your individual needs using CNC control. Further details on request.

Please note for the profiles EPS 1-002 and EPS 1-006:  
These profiles cannot be bent using CNC, but shaping can be achieved by sawing into it:

- Bending radius of sawing > 230 mm

Please note for the profile EPS 1-019:  
These profiles cannot be bent using CNC, but shaping can be achieved by sawing into it:

- Bending radius of sawing > 300 mm

For the profile EPS 1-017 applies for the bending of Retrofit JR including Flat cover profile JR:

- CNC bending radius > 1200 mm
- Sawing bending radius > 230 mm

# EPS

## SYSTEMS

EPS Systems KG  
Obere Leimbach 6  
57074 Siegen/Germany  
Fon +49 (0) 271.338829-00  
[info@eps-systems.de](mailto:info@eps-systems.de)  
[www.eps-systems.de](http://www.eps-systems.de)